

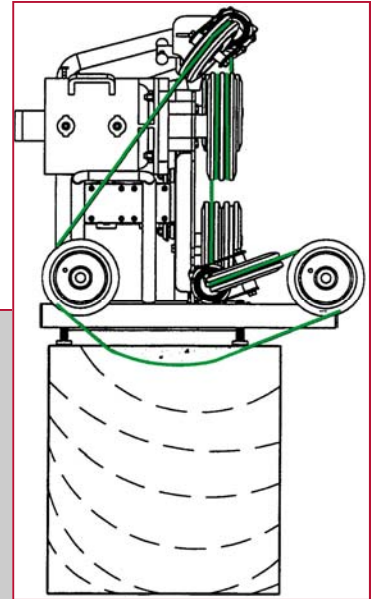

# What's Newz

## “NEW GENERATION” DIAMOND WIRE

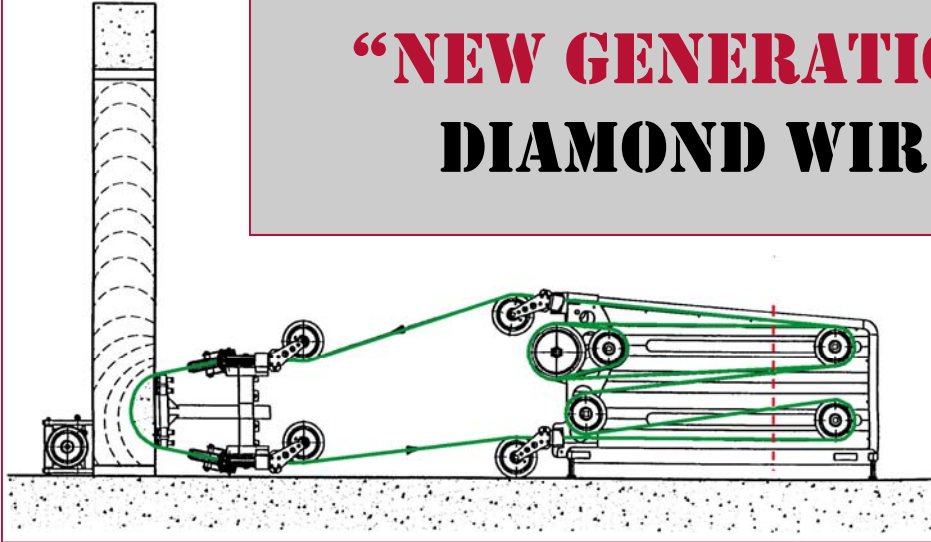

K2's diamond wires are designed for a variety of applications! They're built with heavy duty wire and springs, with impregnated or electroplated beads.

Our wire is then vulcanized for maximum wire protection, resulting in a very flexible and easy to use diamond wire.

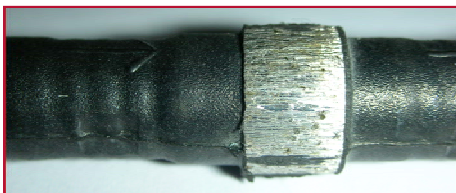
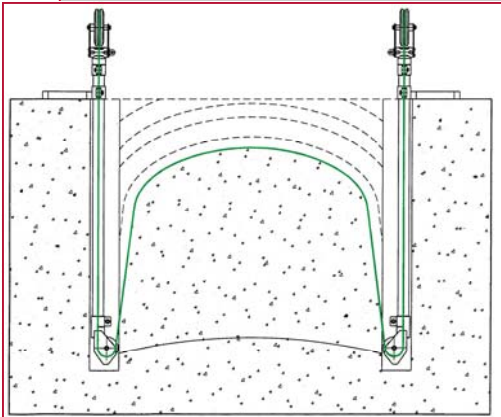

**IMPREGNATED**

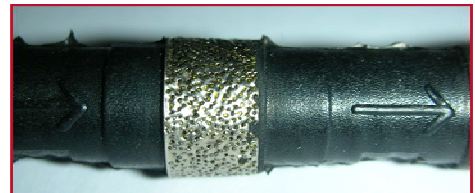

**ELECTROPLATED**

## K2 DIAMOND

# What's Newz



*Diamond Wire*

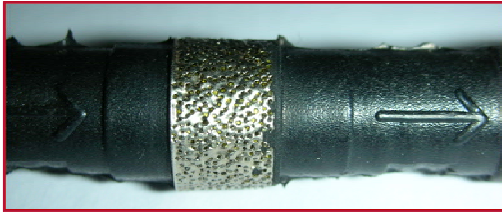

Our New Generation **Electroplated Diamond Wire** is designed specifically for demanding applications like dry and wet cutting in reinforced concrete, and in solid or hollow steel. The beads are made of an annular steel support on which the diamond partials are bonded together by electrolysis, resulting in excellent cutting speed and diamond retention for long life.

Our electroplated diamond wire is perfectly suited for high speed sawing in a large variety of materials. Ideal for lower HP saws and wire saw conversions.

10.5 mm Vulcanized Spring Electroplated Diamond Wire	Spec: VW E V	40 Beads per meter	12 Beads per foot
--	--------------	--------------------	-------------------

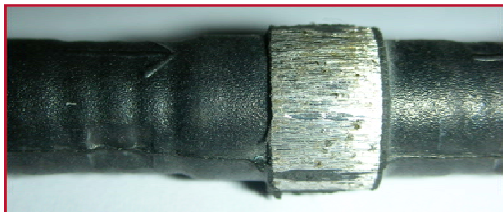

Our New Generation **Impregnated Diamond Wire** is engineered for long life and great cutting speed in a variety of cutting applications.

Each diamond bead is sintered with a unique bond and impregnated with high grade diamond partials, resulting in a high performance diamond wire that gets you maximum performance and value per square foot of cutting in stone, reinforced concrete and other hard materials.

10.5 mm Vulcanized Spring Impregnated Diamond Wire	Spec: VW 5 P	40 Beads per meter	12 Beads per foot
--	--------------	--------------------	-------------------

**K2 DIAMOND**

**800 539-6116**  
[www.k2diamond.com](http://www.k2diamond.com)